

OPERATION, MAINTENANCE AND SPARE PARTS MANUAL

SKIDDING WINCH JL 351P



**READ THIS OPERATION AND MAINTENANCE MANUAL CAREFULLY
BEFORE USING THE MACHINE**

FARMI®
Forest

Farmi Forest Corporation
Ahmolantie 6
FIN-74510 Iisalmi, Finland
Tel. +358 (0)17 83 241
Fax. +358 (0)17 8324 372
www.farmiforest.fi

JL 351P

WARNING SYMBOLS IN THIS MANUAL



- **imminent danger which could cause serious personal injury or death**



- **danger which could cause personal injury**



- **conditions or misuse that could damage equipment or machinery**

NOTE!

- **reminders, such as for performing checks or carrying out maintenance or repair procedures**

INTRODUCTION

This manual includes the information and maintenance instructions required for operating the machine in the optimal manner.

Although you have experience in using this kind of machinery, read the operation and maintenance instructions carefully since they include information enabling efficient and safe operation. Regular maintenance is the best way to guarantee the efficient and economical performance of the machine.



Each and every operator must read, understand, and follow all safety instructions and procedures.

CUSTOMER FEEDBACK

We are happy to receive your opinions and suggestions for improvements by mail, fax or e-mail. All implemented suggestions for improvements will be rewarded.

JL 351P



MANUFACTURER'S DECLARATION OF CONFORMITY

Farmi Forest Corporation
Ahmolantie 6, FIN-74510 IISALMI, Finland

Informs that the machine, launched on to the market

Farmi
(make)

JL 351P
(type)

(serial number)

conforms to the directives 98/37/EC and 89/336/EC, as amended, and the national regulations bringing these directives into force.

In designing the machine, the following unified standards have been applied:

EN 292-2, EN 294, EN 60204-1

In designing the machine, the following national standards and specifications have been applied:

prEN 1553

Iisalmi, Finland
(place)

11.1.2008
(date)

Juha Hallivuori

JL 351P

TABLE OF CONTENTS

SAFETY INSTRUCTIONS	6
STICKERS AND PLATES	10
MAIN PARTS AND ACCESSORIES	13
TECHNICAL SPECIFICATION	14
MOUNTING	15
PRE-OPERATION CHECKS	16
CONTROLS	17
OPERATION	17
PRE-OPERATION CHECKS	18
WINCHING	19
SKIDDING	19
DROPPING THE LOAD	20
TRANSPORTATION	20
MAINTENANCE	21
LUBRICATION	21
CLUTCH ADJUSTMENT	21
ADJUSTING THE ROLLER CHAIN TIGHTNESS	22
ADJUSTING THE DRUM BRAKE	22
REMOVING THE WINCH MECHANISM	22
ASSEMBLY OF THE MECHANISM	23
TROUBLE SHOOTING	24
FRAME	26
MACHINERY	28
PROTECTIVE SCREEN	32
LOWER PROTECTIVE SCREEN	33
COVER OF THE UNIVERSAL SHAFT	33
ACCESSORIES	34

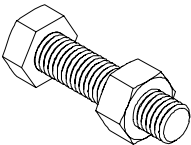
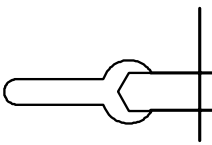
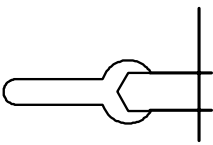
 Thread	 Millimeter	 Inch
M6	10	7/16
M8	13	1/2
M10	17	11/16
M12	19	3/4
M16	24	15/16
M20	30	1 3/16
M24	34	1 7/16

When ordering spare parts, please indicate the machine's type from the machine plate, spare part's order number, description and quantity required.

Example. JL351P, 92820182, pin, 2 pc

JL 351P

SAFETY INSTRUCTIONS

These safety instructions are meant for the owners of FARMI equipment, as well as those who operate, service or repair it.

The instructions help with:

- using the machine safely, appropriately and effectively.
- identifying, avoiding and preventing potentially dangerous situations.

The manufacturer supplies an instruction manual, which must always be available at the place of operation of the machine. Each user must read the safety, maintenance and operating instructions before operating the machine, and comply with these instructions at all times.

Ensure that every operator of the machine is familiar with the content of the instruction manual and situation-specific safety instructions, and has been suitably trained before operating the machine.

The machine complies with technical requirements and applicable safety regulations. However, incorrect use, maintenance or repair of the machine may cause risks.

In addition to the instruction manual, remember to comply with regulations of the local occupational health and safety authorities, and with your country's laws and decrees.

The manufacturer is not liable for damages caused by:

- incorrect, negligent or inappropriate use of the product.
- non-original spare parts.
- normal wear and tear.
- misuse caused by an untrained person's improper actions.
- alterations made without the manufacturer's permission.



Written authorization must be requested from the manufacturer for any alterations to the machine.

STARTING

- Familiarize yourself thoroughly with the use, operation and controls of the machine and its equipment before starting.
- Familiarize yourself with the capacities and limitations of the machine and its equipment.
- Do not use the machine unless you are completely familiar with its operation.
- Be aware of the machine's danger zones.
- During operation, prevent bystanders from entering the danger zone.
- Ensure that each operator has the necessary safety equipment, such as a helmet, safety goggles, work safety boots and suitable protective clothing.
- Never wear loose clothing around moving parts. Protect long hair!
- Ensure that work is carried out according to the stipulations of applicable occupational health and safety legislation.
- Before starting up or using the machine, ensure that it cannot cause a risk to other people or property.
- Perform a safety check on the machine before every use. If you observe any faults or deficiencies, repair the machine immediately.
- Before operating the machine, ensure that there are no foreign articles in it.
- Place the machine on a hard, level surface for operation. In the winter avoid working in slippery areas.
- Before operation, ensure the machine is properly connected.
- Never use a faulty or deficient machine.

JL 351P

OPERATION



Many occupational accidents take place in abnormal circumstances. Therefore it is important to take into account all the possible circumstances that may arise during operation of the machine.

- Depending on the machine's type, it will have diverse safety devices and protectors. These are meant to protect the machine and its operator, and they must never be removed or altered. Never start up or use the machine without all the safety devices and protectors in place. Also check the universal joint's safety equipment and joints.
- Never insert any body part into the machine with the engine running.
- If any faults arise that may jeopardize occupational safety, turn off the machine.
- During operation, the machine's operator is responsible for safety in the whole work area. Work may not be carried out in the presence of any factors that jeopardize occupational safety.
- Exercise extreme caution when hitching / unhitching the machine from a tractor/trailer.



The machine's operator must have constant, unobstructed visibility of the work area. If this is not possible, the operator must work with an assistant.

- Look out for moving parts when the machine is in operation.
- Secure the machine against unauthorized and accidental operation (e.g. moving when parked) whenever it is left unattended.
- Never leave the machine running unattended.
- Avoid causing fast, stroke-like loading.
- Never exceed the given operating values.
- All safety and warning signs on and in the machine must be legible and intact.
- The machine may not be operated by persons who are unwell or under the influence of drugs or alcohol.

MAINTENANCE

- The machine may only be serviced and repaired by professionals.
- Electrical and hydraulic faults may only be repaired by authorized professionals.
- In cases requiring welding, contact the manufacturer.
- Turn off the tractor engine and disconnect the universal joint before beginning service or maintenance actions.
- Ensure that there is no pressure in the hydraulic system.
- Take out the key from the tractor's ignition for the duration of the servicing or maintenance. Check that the power is off from the machine you are working on.
- When servicing the machine, place it on a level surface and ensure that it cannot be moved.
- Observe the service intervals and annual safety inspections.
- All spare parts and equipment must fulfill the manufacturer's requirements. This can be guaranteed by using original parts.
- Put all safety devices back into place immediately once servicing or maintenance is complete.



When lifting the machine, check that the lifting/hoisting equipment is in perfect working order. Check the weight of the machine before lifting it. Choose lifting trajectories so that they do not cause any danger.

Many countries have specific legislation on lifting, hoisting cables and hoists. Always comply with local safety regulations.

OILS AND LUBRICATION

- Always use the oil types recommended by the manufacturer. Other types of oil may cause faults or improper operation of the equipment, which could lead to serious damage to people or property.
- Never mix different liquids or oils.
- Always follow the manufacturer's lubrication instructions.
- Use control equipment carefully until the hydraulic oil has had time to reach its operating temperature.

JL 351P

SAFETY INSTRUCTIONS FOR HYDRAULIC CIRCUITS

1. Work on hydraulic equipment may only be carried out by professional hydraulic engineers.
2. Be cautious when using the equipment in cold conditions.
3. Check the machine for leaks. Do not use the machine if there is a leak from any system. Check all hydraulic hoses – particularly those which are bent during use – and replace any that are in poor condition or have leaks. Ensure that all joints are tight and that the lines are not damaged. Check that all protective caps and filler caps are closed properly.
4. Check that all hose connectors, lengths and qualities comply with applicable requirements. When replacing or repairing hoses, use original parts or hoses and connectors recommended by the manufacturer. Check particularly that the pressure classes of the hoses and connectors are suitable to the operating pressure levels.
5. Check that all safety devices such as pressure relief valves, etc., are in place and work properly. Familiarize yourself with their use. Safety systems may never be bypassed.
6. Check the main hydraulic parts daily, and always after a fault. Replace any damaged parts immediately.
7. If a component is damaged, clean it before repairing it. Do not use solvents when cleaning parts.
8. Do not attempt to carry out repairs that you are not fully familiar with.
9. Never carry out repairs of the hydraulic circuit when the system is pressurized. When pressurized, the oil spray can penetrate the skin and cause mortal danger.
10. Never work below a device or component that is only being held up by hydraulics. Use separate supports when carrying out maintenance or repairs. Do not disconnect cylinders or their valves until the machine is well supported.
11. Most hydraulic oils do not evaporate easily. Risk factors include hot oil, spills and oil mist (pressurized).
12. If oil gets into your eyes, rinse with plenty of water and contact a doctor.
13. Avoid prolonged or repeated contact with your skin.
14. If sprays or contact with the skin cannot be avoided, use protective gloves, goggles and clothing as necessary. Do not use oily clothing.
15. Avoid discharging hydraulic oil into the environment, as it can pollute waterways and the groundwater. When working in ecologically vulnerable areas, use biofuel.
16. Store the oil in sealed containers provided by the manufacturer. Try to transfer the oil directly from its container into the tank.
17. If the oil must be passed through other containers, ensure that they are completely clean. Caps, funnels, sieves and filling holes must also be clean.
18. Never store oil outdoors, as water could condense in it.
19. Always dispose of oil in a suitable container, never into the environment!

JL 351P

SAFETY INSTRUCTIONS FOR WINCHES

- Check that the wire cable is in good condition before using the winch (check for corrosion, sharp bends, breakage and thickness of strands). If a cable snaps, it can whip towards the operator or away from the winch.
- Operate the winch with a guide cable at least 2 meters away to the side of the machine. Do not operate the winch from the tractor cabin unless a safety net has been installed.
- When winching downhill, the pulling must be done from the side using an additional idler.
- When winching on a hill, do not follow the load from below.
- Side-winchng must not be done at angles of more than 30 degrees.
- It is extremely dangerous to be in the space between a load attached to the wire cable and the winch.
- Check that all bystanders are at a safe distance of at least 15 meters whenever the machine is running. Place warning signs on approaching roads.
- Never touch the wire cable by hand during winching.
- The maximum load must be adjusted to conditions.
- Check that the winching chains are carefully attached. Do not attach the wire cable directly to the load.
- The safety coefficient must be 2.5 for cable-type fasteners and 2 for chain-type fasteners.
- Disconnect the transmission before examining the machine in the case of any faults.
- Ensure the wire cable is as short as possible during transport.
- The winch may only be used for winching and hauling. Do not use the winch for lifting loads.

JL 351P

STICKERS AND PLATES

The following plates and labels must be correctly attached to the machine.
Missing safety plates / labels must be replaced immediately.

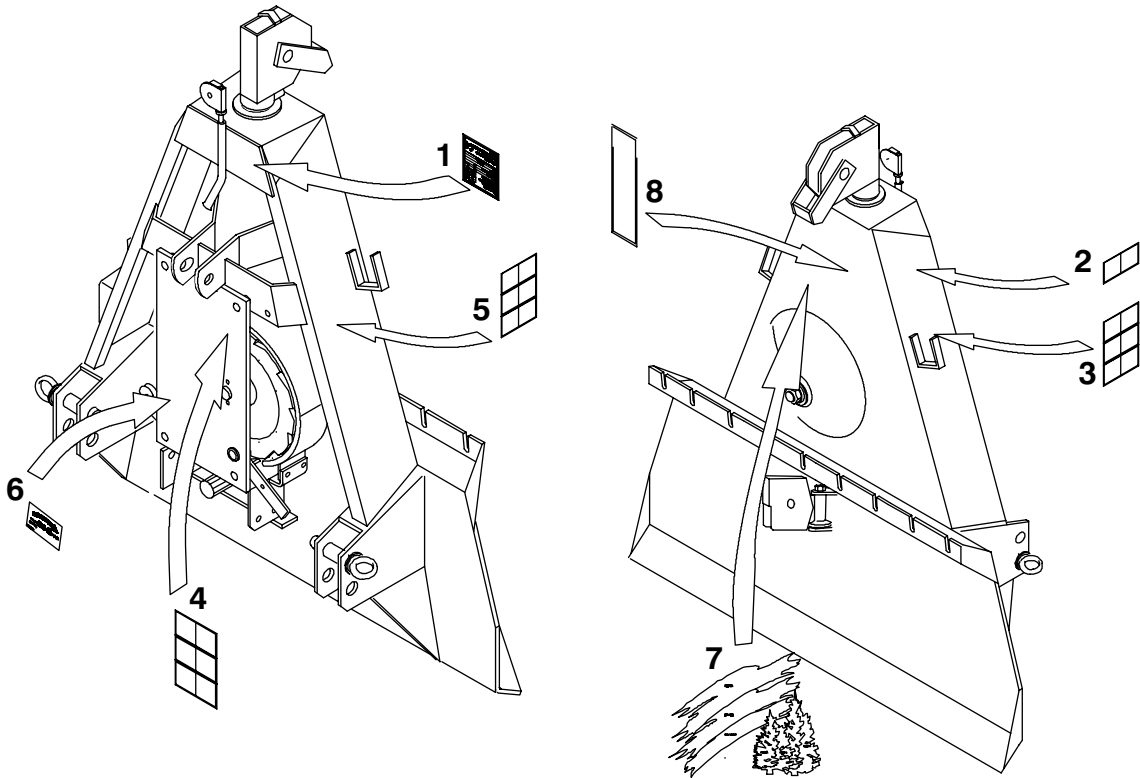

Farmi Forest Corporation			
Ahmolantie 6 FIN-74510 IISALMI FINLAND			
			CE
TYPE	FARM WINCH		
MODEL	JL 351P		
DIN 15020 GROUP	EM	1	4-1012010
MAX. ALLOWED PULL EMPTY	kN	35	
MAX. ALLOWED PULL FULL DRUM	kN	13	
SERIAL NO.			
YEAR OF MANUFACTURE		20	
POWER NEEDED	kW	10	
MIN. DIAMETER OF CABLE	mm	9	
MIN. BREAKING LOAD OF ROPE	kN/mm ²	1,96	
WEIGHT	kg	170	

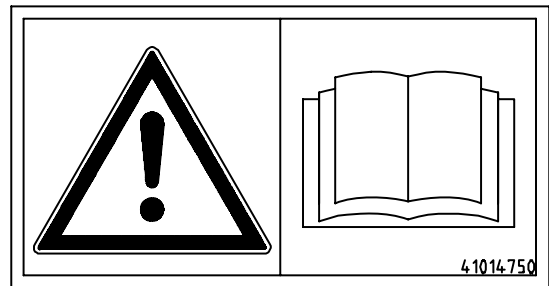

2. Note! See manual for operation and maintenance. (41014750)

1. Machine plate JL351P (41012010)

JL 351P

STICKERS AND PLATES

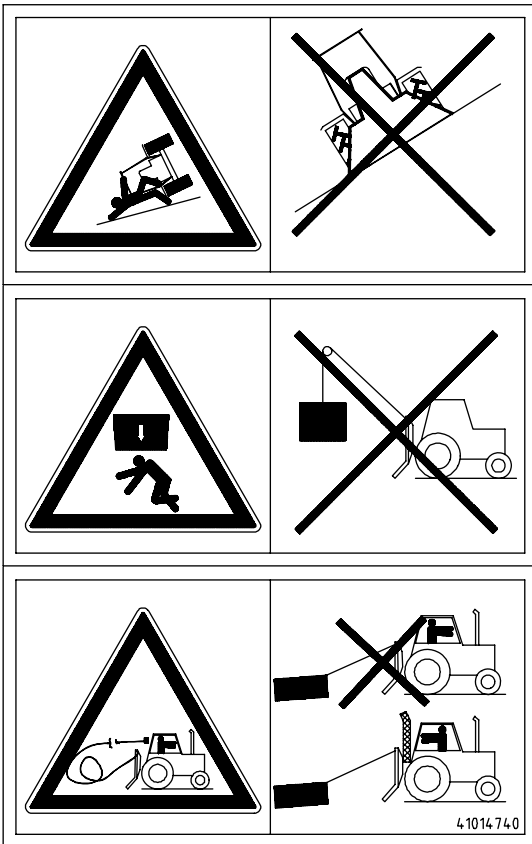

3. Nr 41014740

Falling danger!
Do not work in an oblique position.

Crushing danger!
Do not use the winch for the lifting.

Watch out for a breaking cable!
Always use the protective screen.

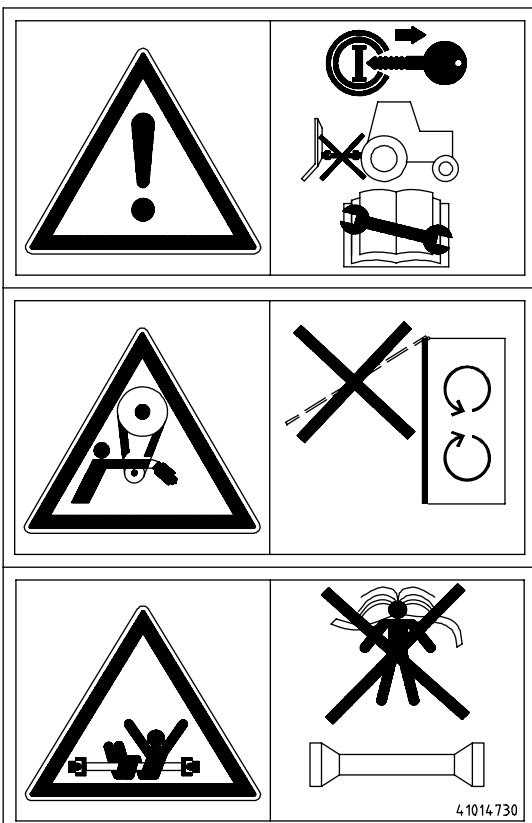

4. Nr 41014730

Note!
Before doing maintenance work turn off the motor, remove the ignition key and disengage the P.T.O.

Accident danger!
Keep the safety equipment where it belongs.

Winding danger!
Do not wear too loose clothes and keep the hair bound inside the cap.

JL 351P

STICKERS AND PLATES

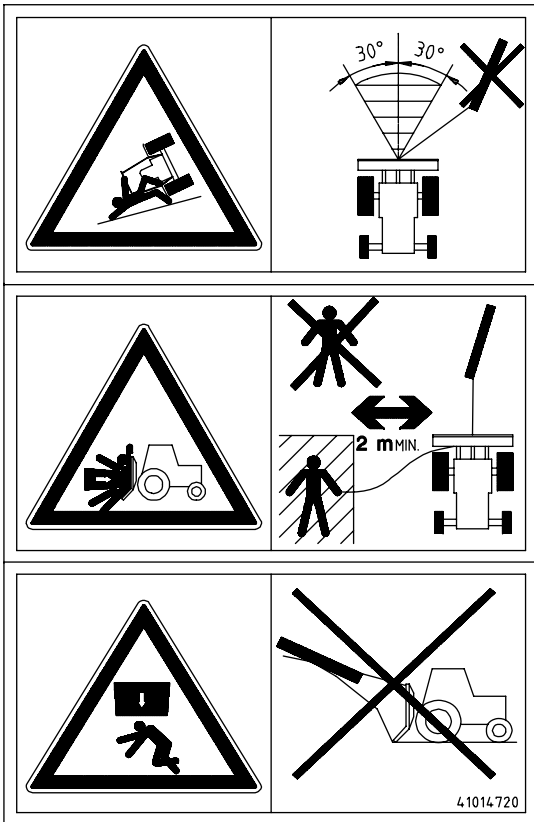

5. Nr 41014720

Falling danger!

Do not winch at sideways angles exceeding 30 degrees.

Crushing danger!

Do not stand in front of the winch when working.

Stand on the side at a distance of at least 6 ft from the winch.

Crushing danger!

Do not winch downhill.

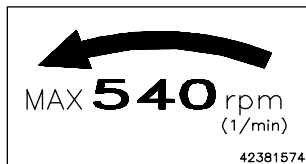

6. Maximum rpm (42381474)

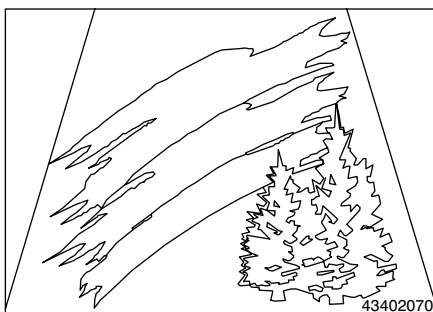

7. METSÄ-sticker (43402070)



8. FARM I-sticker (30730501)

JL 351P

MAIN PARTS AND ACCESSORIES

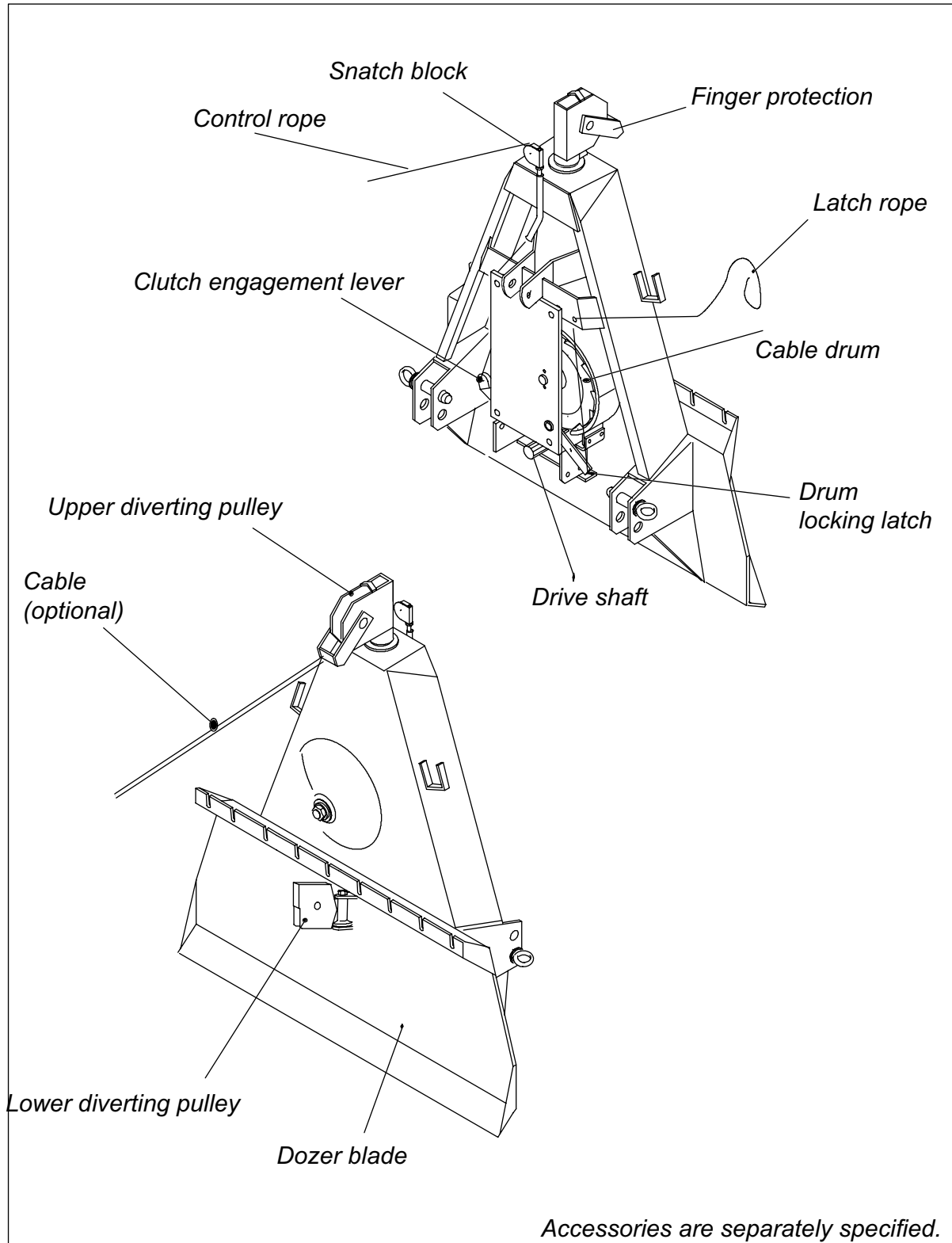

JL 351P

TECHNICAL SPECIFICATION

TECHNICAL SPECIFICATION		JL351P
Tractive power	Cable drum empty (Maximum)	35 kN
	Cable drum full (Minimum)	13 kN
Cable capacity	Ultimate strength of the cable	1,96 kN/mm ²
Winching speed	540 rpm	0,5 - 1,3 m/s
Weight(without cable)		170 kg
Clutch		Mechanical friction plate clutch with heat sink
Power transmission		Universal shaft from tractor
Mounting		To 3-point hitch(Kat.I)
Power needed		min. 10 kW (14 hp)

DIMENSIONS

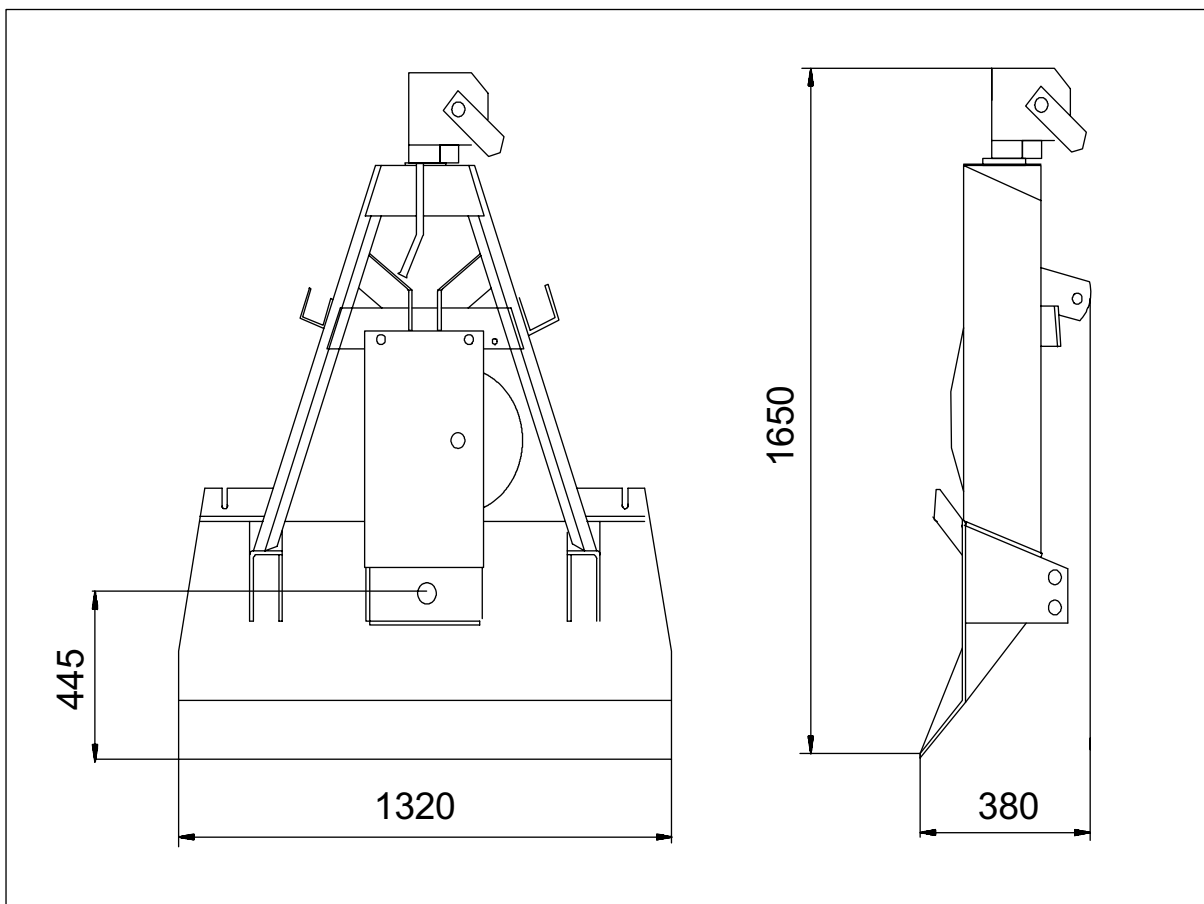

JL 351P

MOUNTING

MOUNTING TO THE 3-POINT HITCH

The winch can be mounted to the 3-point linkage of any tractor. Power transmission is obtained through universal shaft from tractor.

ASSEMBLY OF THE PTO SHAFT



If the PTO shaft is too long it may get pressed when the three point hitch is lifted up. This may cause damage to the bearings of the winch or to the PTO of the tractor.

The PTO shaft must not be too short in any position.

The PTO length is suitable, if the pipes do not reach the bottom.

PTO is optional equipment.

1. Mount the winch to the 3-point hitch of the tractor.
2. Raise the winch high enough to get the PTO shaft of the tractor and the winch to a horizontal level.
3. If you have a shortened PTO shaft available, put one end into the drive shaft and check that the distance of the locking of the other end. Take into account the additional clearance of approx. 20 mm (0.78").
4. Fasten the other end of the PTO shaft in its place and also move the winch sideways at the same time securing that the axis does not base.

SHORTEN THE DRIVE SHAFT



Both PTO halves must be shortened by equal amounts.

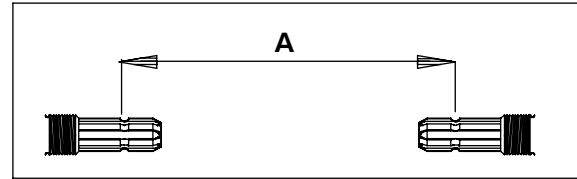

Fig. 1. Measure A when the drive shafts are nearest to each other.

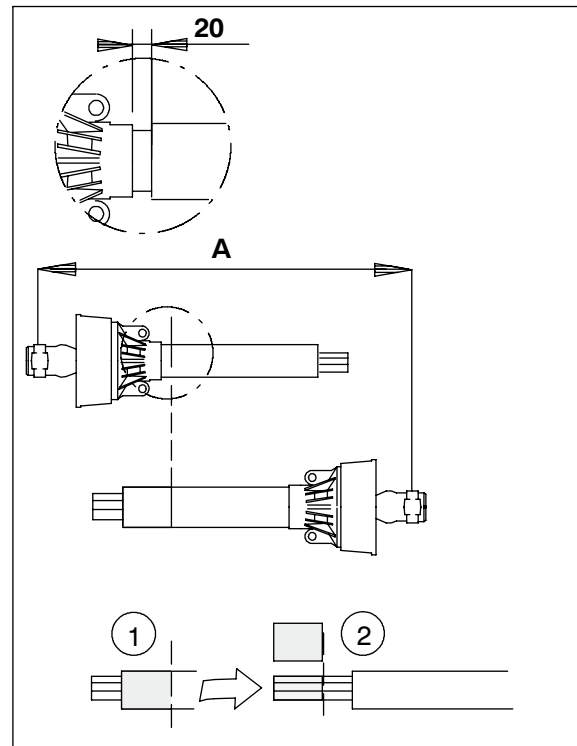

Fig. 2. Shorten the drive shaft

- First cut the thicker cover to a correct length (1). Remember 20 mm (0.78") clearance. Then cut away the same amount from the form pipe. Make a similar shortening to the second half of the PTO shaft. Remove the burr with the file.
- Connect the PTO shafts within each other. Make sure by moving elevator carefully up and down that the shortening of the axis is sufficient. Check that the axis have 20 mm (0.78") latitude.

JL 351P

FASTENING THE CABLE TO THE DRUM

1. Tape the cable end to prevent loosening of the core wires.
2. Pass the cable through the hole in cable guard, over the upper snatch block and then inside the winch.
3. Insert the cable from behind the roll of the drum brake.
4. Pull the cable onto the drum from the left hand side (the same side as the clutch lever).
5. Pass the cable end through the hole in the drum plate, pull about 15 cm (6"), and insert under the wedge of the cable lock device. See fig. 3.
6. Tighten the cable lock screw.
7. Winch the cable on the drum. **BUT REMEMBER THAT THE CABLE HAS TO BE LOADED HEAVILY, WHEN WINCHING THE CABLE BACK ON THE DRUM.**

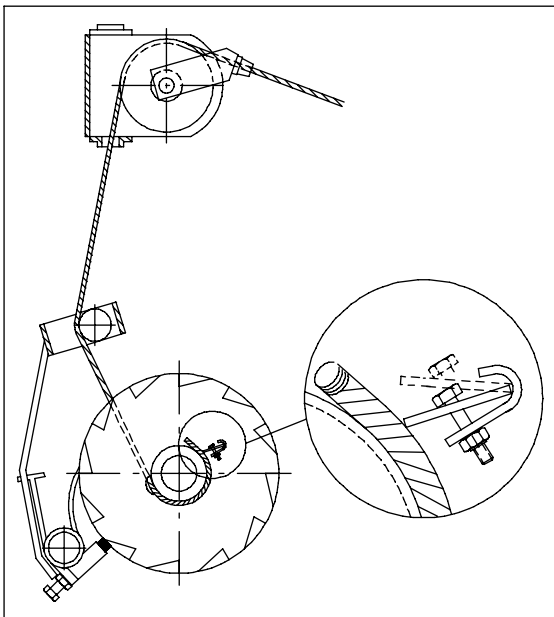

Fig. 3. Fastening the cable

Do not use longer cable than needed. With correct length you achieve good pulling strength and proper winding of the cable.

PRE-OPERATION CHECKS

CABLE

Check that:

- the cable is faultless (breakage risk).
- there are no twists or kinks (breakage risk) in the cable.
- the cable has been properly fastened to the winch.

WINCH

Check that:

- all the pins and lynch pins are in place.
- all bolts and nuts have been tightened.
- roller chain is tight.
- the drum brake has been properly adjusted.
- the clutch has been correctly adjusted.
- lubrication is carried out correctly. See lubricating instructions.

MOUNTING TO THE TRACTOR

Check that:

- the tractor's top link point is locked. (with the help of a support, if necessary).
- the pins are properly secured.
- the sway bars or turnbuckles are suitably tight.
- the PTO-shaft is suitably long, properly fastened and the shield chains attached.
- the support leg of the winch is turned upward.

JL 351P

CONTROLS



Get acquainted with the controllers of the winch before the use, tests the stopping functions of the winch and the tractor and all other functions. Each function has to be in perfect condition.

PULLING OUT THE CABLE

- The cable can be freely drawn out if the drum has not been locked with a latch.

WINCHING

- The winch is equipped with a clutch, which will be used by the control rope. When the user draws the control rope, the winch begins to draw in the cable. Winching will stop when the rope is released.
- The end of the cable drum is equipped with a friction clutch, which slips, if the load is too heavy. This prevents cable break or damages if the load gets caught.

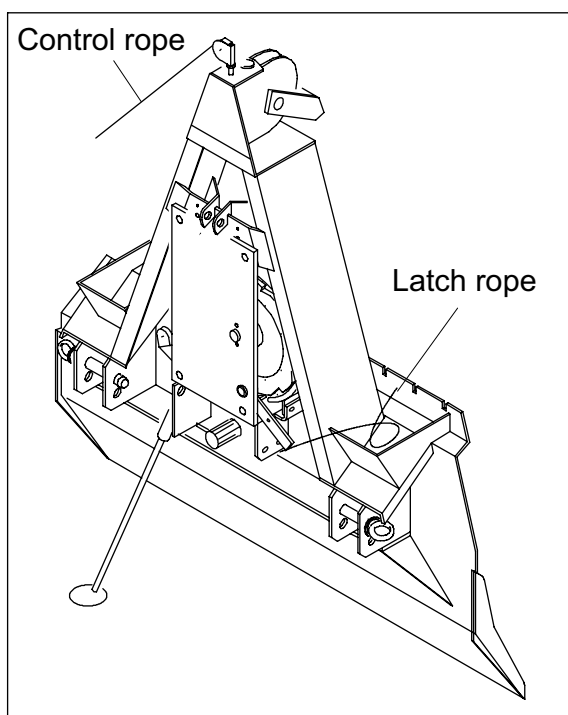

Fig. 4. Controls

OPERATION

SAFETY PRECAUTIONS



Read the operation instructions before operating this machine! It is the owner's responsibility to instruct all equipment operators and support personnel in the operation of this winch.

1. Choose a horizontal, hard based skidding route for the tractor. Avoid steep slopes, especially when winching from the side. Check that the winching trail is clear and that the tractor's parking brake is on. Do not run the tractor at a high idle when winching. Maximum P.T.O speed is 540 rpm. Ensure that the logs can be drawn freely. Be especially careful when working on slopes. Avoid winching sideways at angles exceeding 30 degrees. Use snatchblock which is fastened to the tree if needed. (See fig. 7.)
2. The safest place for the operator is at the back left side of the winch, allowing good visibility. See fig. 21. Take care that there is no one in the working area.
3. The tractor must have a ROPS cab and front end weights.
 - Always position the tractor on a flat ground in line with the direction of the pull (see fig. 5.). Avoid working in steep terrain. Ensure nothing is blocking the path of trees.
 - Avoid an unnecessarily strong pulls, the tractor may roll over.
 - Adjust the tractors rpm's according to the conditions.
 - Use a shield between the seat and the winch (e.g. safety cab or protective screen) if you run the winch from the tractor seat.
 - Use agreed signals when working in groups.
4. When you use a light tractor, there is a very big risk that the tractor will roll over. To avoid that risk, you must add extra weight to the front of the tractor.

JL 351P

- The falling danger of the tractor can be reduced by winching through the lower snatchblock.

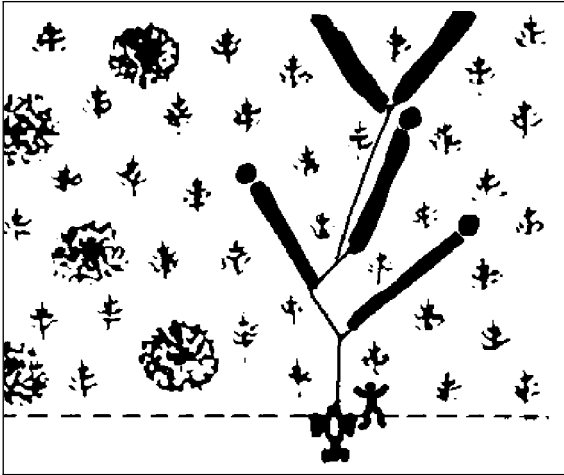

Fig. 5.

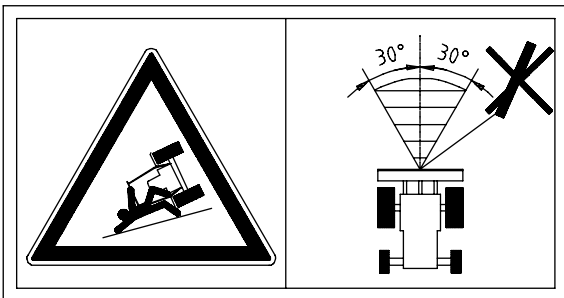

Fig. 6. Do not winch sideways at angles exceeding 30 degrees. The tractor can tilt.

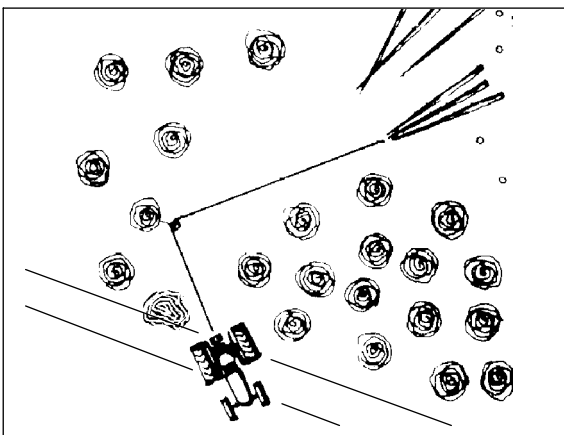

Fig. 7. Use a snatchblock to avoid winching sideways.

PRE-OPERATION CHECKS

MOUNTING AND USE OF THE LOWER SNATCHBLOCK

- Usually the logs are winched in through the upper pulley of the winch. This lifts the logs and they dig less into the ground. The weight of the load also pushes the blade into the ground thus anchoring the winch and the tractor to the ground.
- The winch has a lower snatchblock. The main use of the lower snatchblock is to lower the pulling point. This enables larger loads to be skidded out. For skidding out the load the cable is transferred to the lower snatchblock.
- Several logs can be hooked up and winched in at one time by means of keyhole sliders on the cable. The skidding chain should have a pin on the end, which makes it easier to pass the chain underneath the tree. See fig. 8.



When using the lower snatch block make sure that it follows the direction of the cable. Otherwise the cable will be damaged, when it is pressed between the snatch block and the lower snatchblock frame.



When winching an unloaded cable, make sure that the finger guard doesn't rise up with cable and doesn't cause cable to crosscut.

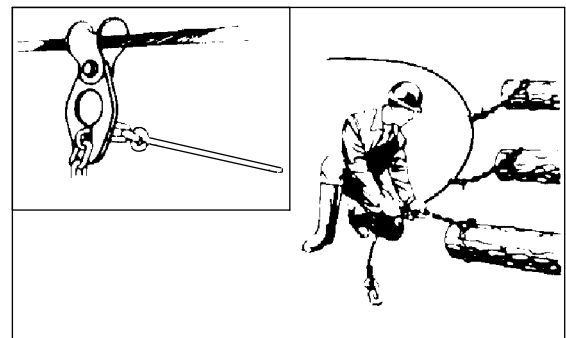

Fig. 8. Use a keyhole sliders to winch several logs at one time.

JL 351P

WINCHING



Before using the winch, you have to pull the cable completely out of the drum and winch the cable back on the drum with a heavy load. Otherwise the cable will be damaged.

- Park the winch and tractor on level, stable ground. Lock the brakes of the tractor before winching. Lower the 3-point hitch so that the dozer blade anchors the winch to the ground. See fig. 9.



Do not let the dozer blade sink too deeply into the ground, so that the PTO shaft is not damaged.

- Before using the skidding winch, make sure that the lower snatch block, the upper snatch block and the finger guard move freely.

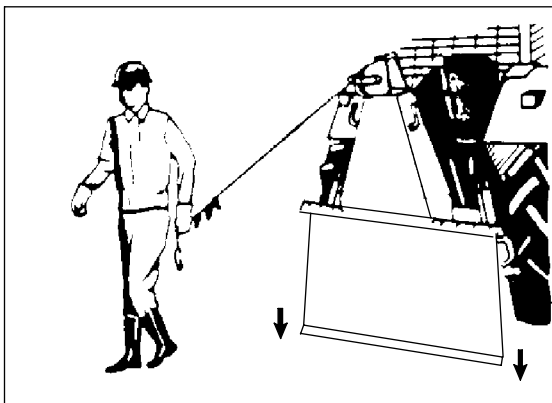

Fig. 9. Anchor the dozer blade to the ground.

1. Draw the cable to the load but avoid twitches. Do not draw out too much cable to avoid loose spaces when the cable is reeled in.
2. Start the tractor, turn the PTO on. Use the winch with the control rope and stand in a safe place at a distance of at least 2 m (6 ft) from the winch. Use the upper snatchblock when winching.
3. Operate the clutch firmly. Avoid sliding the clutch to avoid warming of the clutch. Stop winching by letting go of the control rope for the leave. The clutch will slip when the load is

heavier than the selected pull. This prevents damages to the cable or winch. Avoid extra large loads. The winding speed depends on the number of revolutions of the tractor. Do not wind too fast.

4. Stop winching when the logs are at about 1,5-3 m (5-10 ft) from the tractor. Install the cable on the lower snatch block.

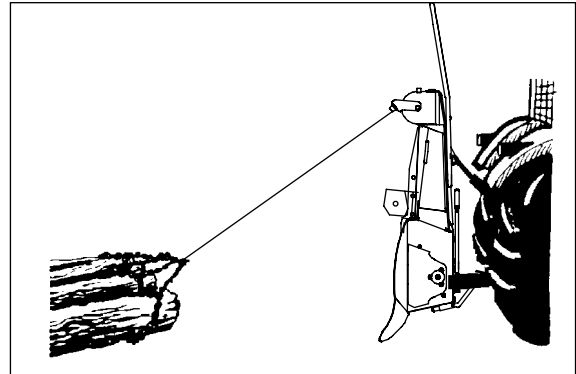

Fig. 10. Winching over the upper snatchblock

SKIDDING

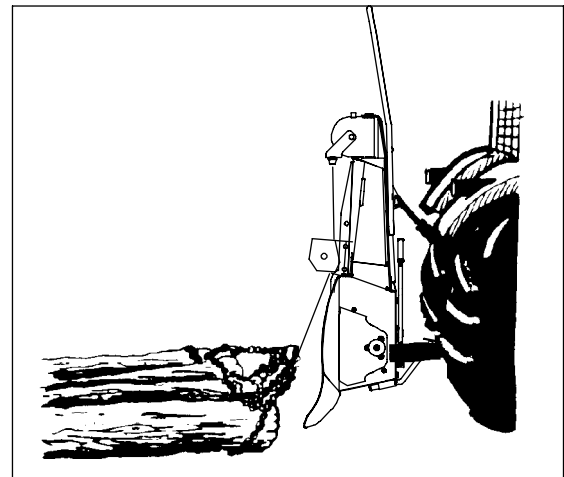

Fig. 11. Cable on the lower snatchblock

1. Turn the P.T.O on. Pull the clutch control rope and winch the logs to the pulley. Keep the tension on the cable and pull the thinner rope that operates the brake ratchet. Stop pulling on the clutch rope first. The load is now locked in place. Alternatively the skidding chains can be attached to the notched beam.
2. Turn off the P.T.O.
3. Raise the 3-point hitch so that the logs come off ground (fig. 12.).
4. Move the logs to the desired place.

JL 351P

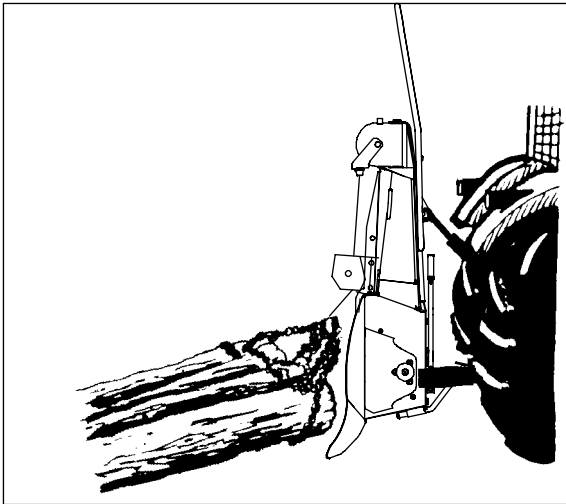

Fig. 12. Winching over the lower snatch block

WORKING IN ROUGH TERRAIN

Drop the load before you reach bad terrain. Drive through the bad spot. Winch in the load again (Fig. 13.).

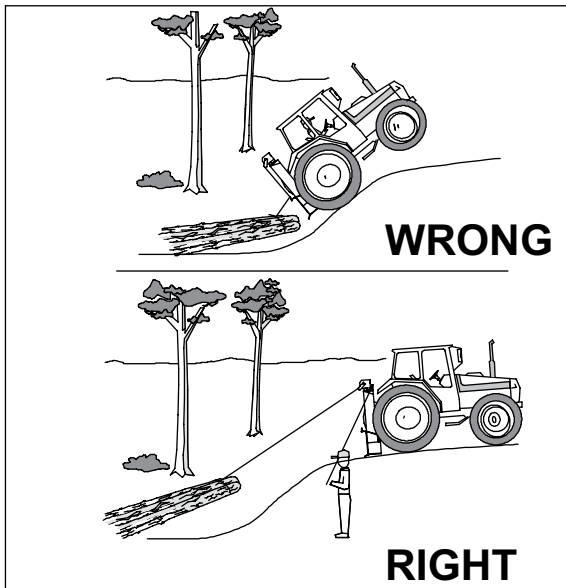

Fig. 13. Driving through bad terrain

IF YOU GET STUCK WITH THE TRACTOR

1. Drop the load. Drive the tractor to firm ground. Winch in the load.
2. If you cannot move the tractor, release the load and winch the tractor out. When winching the tractor out, always run the cable under the lower pulley.

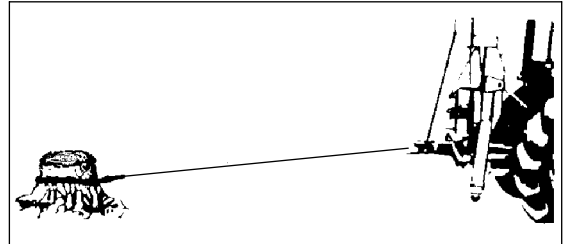

Fig. 14. Winching the tractor out

DROPPING THE LOAD

1. Let down the 3-point hitch.
2. Pull the clutch rope until the brake ratchet releases, then stop pulling the clutch rope. The logs drop to the ground.

TRANSPORTATION

The cable should be run under lower snatchblock and locked in place for transportation of the winch.

JL 351P

MAINTENANCE

SAFETY



Disengage the P.T.O and turn the tractor off before you service the winch, remove the keys so the tractor cannot be started up accidentally.

LUBRICATION



Do not oil the drive chain, because the oil will work its way to the clutch!

The cable drum, main sprocket and snatchblock are fitted with self lubricating bearings.

Following points require lubrication:

1. Grease the drum clutch parts after every 500 working hours. Always use good quality lubrication grease.
2. Grease the PTO-shaft regularly and always before use as shown in figure 15.
3. Grease the drum chain lightly (not with oil) after every 50 working hours with spray type, hardening chain grease. Wipe off the excessive grease.

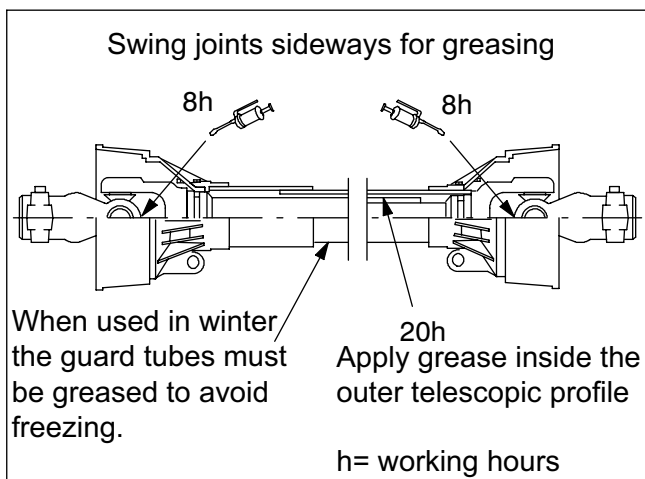

Fig. 15. P.T.O shaft lubrication

CLUTCH ADJUSTMENT

1. Loosen the nuts A and B at both ends of the drum axle. Wrench opening 1 7/16" (36 mm).
2. Adjust the clutch by turning the axle C with 9/16" or 14 mm wrench. The clutch tightens clockwise, loosens counterclockwise. Turn max. 1/4 turn.
3. After adjustment retighten the nuts A and B on the ends of the drum axle.
4. Pull the control rope. The lever should move up 1.5" (4 cm) before the clutch engages. If the clutch engages earlier loosen the clutch setting.

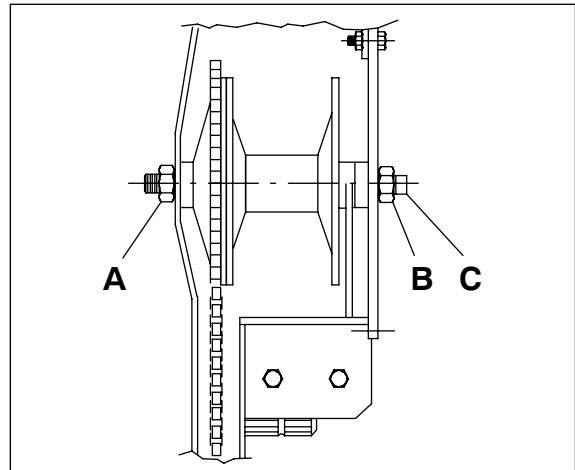

Fig. 16. Clutch adjustment

JL 351P

ADJUSTING THE ROLLER CHAIN TIGHTNESS

Roller chains tightness adjustment is carried out by moving the chain tightener. See fig. 17.

1. Loosen the two bolts holding the chain tightener (11/16" or 17 mm wrench).
2. Adjust the chain tightness by moving the chain tightener towards or away from center.
3. Tighten the nuts.
4. Check that the chain tightener runs on the rollers.

NOTE! Do not over tighten the chain.

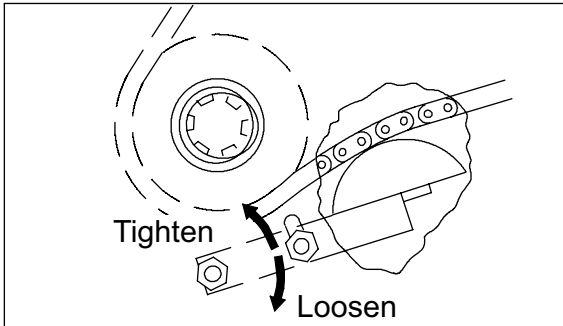

Fig. 17. Tightening the roller chain

ADJUSTING THE DRUM BRAKE

Adjust the drum brake so that it slows down the drum slightly while pulling out the rope. This will reduce risk of tangling and backlash.

- To increase the braking effect tighten the adjustment bolt. See fig 18. To decrease the braking effect loosen the adjustment bolt.

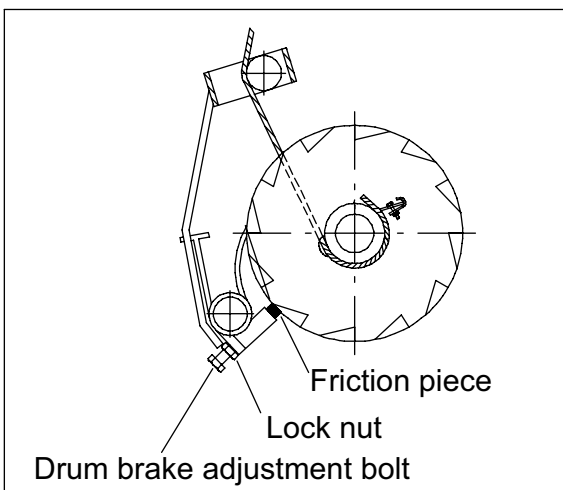

Fig. 18. Drum brake adjustment

REMOVING THE WINCH MECHANISM

The whole winch mechanism can be removed in one piece from the frame. To remove the winch mechanism from the winch (e.g. in order to change the roller chain) follow the instructions below:

1. Park the winch on a level, stable ground so that it leans a little backwards.
2. Remove the cable.
3. Remove the fastening bolts (fig. 19 pos. B) beside the drive shaft. Socket size 24 mm (15/16").
4. Remove the two bolts (fig. 19 pos. A) at the upper edge of the cover plate. Socket size 24 mm (15/16").
5. Remove the drum axle nut (fig. 19 pos. C) and the washer. Socket size 36 mm (1 7/16")
6. Pull out the winch mechanism. Weight 148 lbs (67 kg).

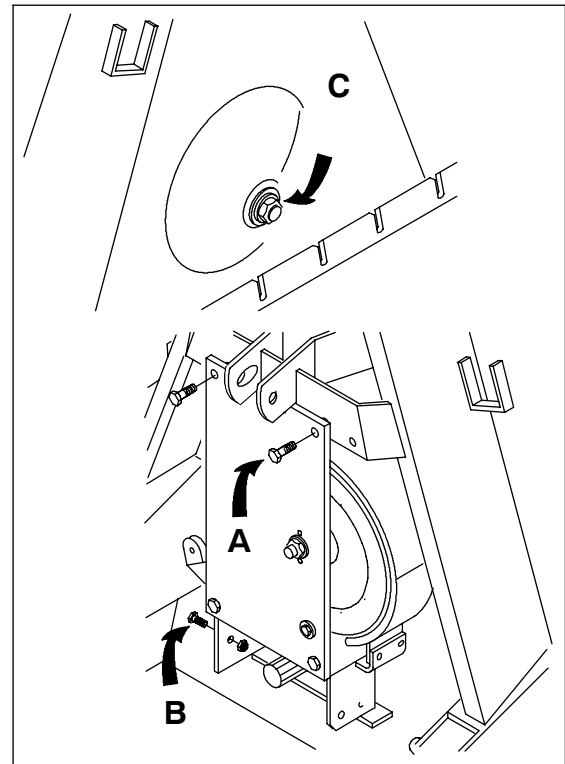

Fig. 19. Removing the winch mechanism

JL 351P

ASSEMBLY OF THE MECHANISM

Make sure that the both pressure bearings are installed in a correct position, that is, the bearing with bigger internal diameter should be facing the cable drum (figure 21). Make sure that the position of the two clutch engagement halves is correct (fig. 20).

1. Place one of the clutch engagement halves on the working table so that the handle is at 8 o'clock position and the 3 slanted surfaces face up.
2. Grease the 3 slanted surfaces with vaseline and place the 3 rollers on the bottom of the slanted surfaces so that the thin ends point towards the middle. The other clutch engagement half (without handle) has 3 slanted surfaces on one side and two holes drilled on the other side (fig 20). Two studs on the back of the front plate will fit into these holes later on when the winch is assembled.
3. Place one clutch engagement half (without the handle) so that the halves bottom out when the handle is at 8 o'clock position and the two holes are at 12 o'clock and 6 o'clock (fig. 20). Be careful, there is only one correct position! Tape the halves together so that they will stay together when you mount them on the drum axle.
4. Install a protective plate. Check the clutch adjustment.

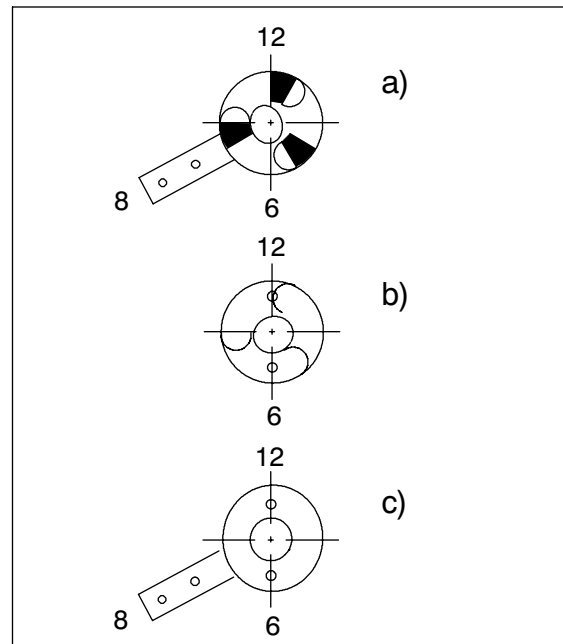

Fig. 20. Reassembling of the clutch engagement halves

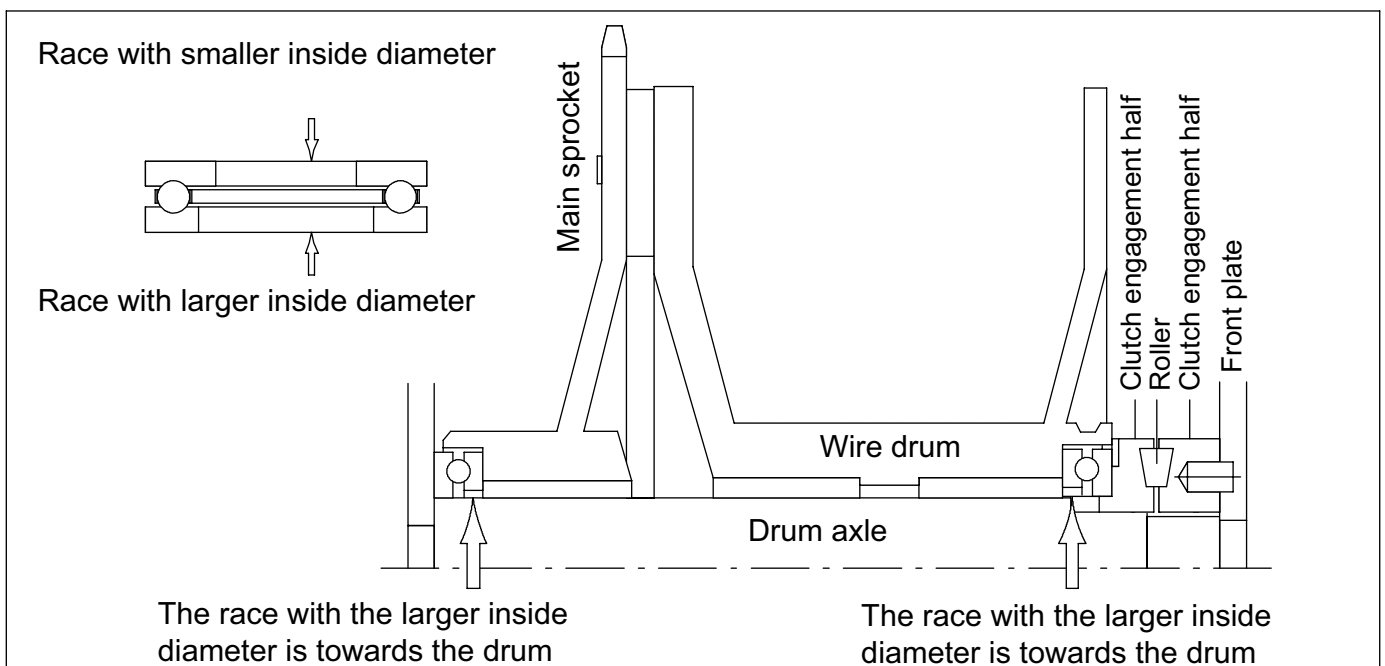

Fig. 21. Correct positioning of the thrust bearings

JL 351P

TROUBLE SHOOTING

CONDITION	POSSIBLE CAUSE	REMEDY
Hard to pull the cable out	Drum brake is too tight.	Loosen the drum brake. See instructions from item "Adjusting the drum brake".
Cable gets tangled on the drum.	Cable too loose on the drum. The cable is pressed between loose loops.	Loosen the pin and pull the cable from the reel with the help of a tractor. Reel the cable tightly back in with the help of the load.
Cable develops kinks.	Cable brake too loose	Tighten the drum brake. Tighten cable on the drum by pulling out the cable and by winching with a heavy load.
Roller chain comes off.	Roller chain too loose, some part is broken or the aligning is incorrect.	Check the alignment of the chain. Check possible damages. Adjust the roller chain, change if necessary. See chapter "Adjusting the roller chain".
Rattling sound	Roller chain too tight, some part is broken or the aligning is incorrect.	Check the alignment of the chain. Check possible damages. Adjust the roller chain, change if necessary. See chapter "Adjusting the roller chain".
Insufficient pull on the cable	Normal wear of the clutch. Minimum thickness of the clutch plates is 7 mm.	See chapter "Clutch adjustment"
	Oil or grease in the clutch	Disassemble and clean the parts.
	Clutch too loosely adjusted	Adjustment of the clutch. See chapter "Clutch adjustment"
Tractor slides backwards when winching	Parking brakes are not on. Dozer blade does not anchor the unit firmly to the ground.	Lock on the parking brakes. Lower the winch all way to the ground.

JL 351P

FRAME

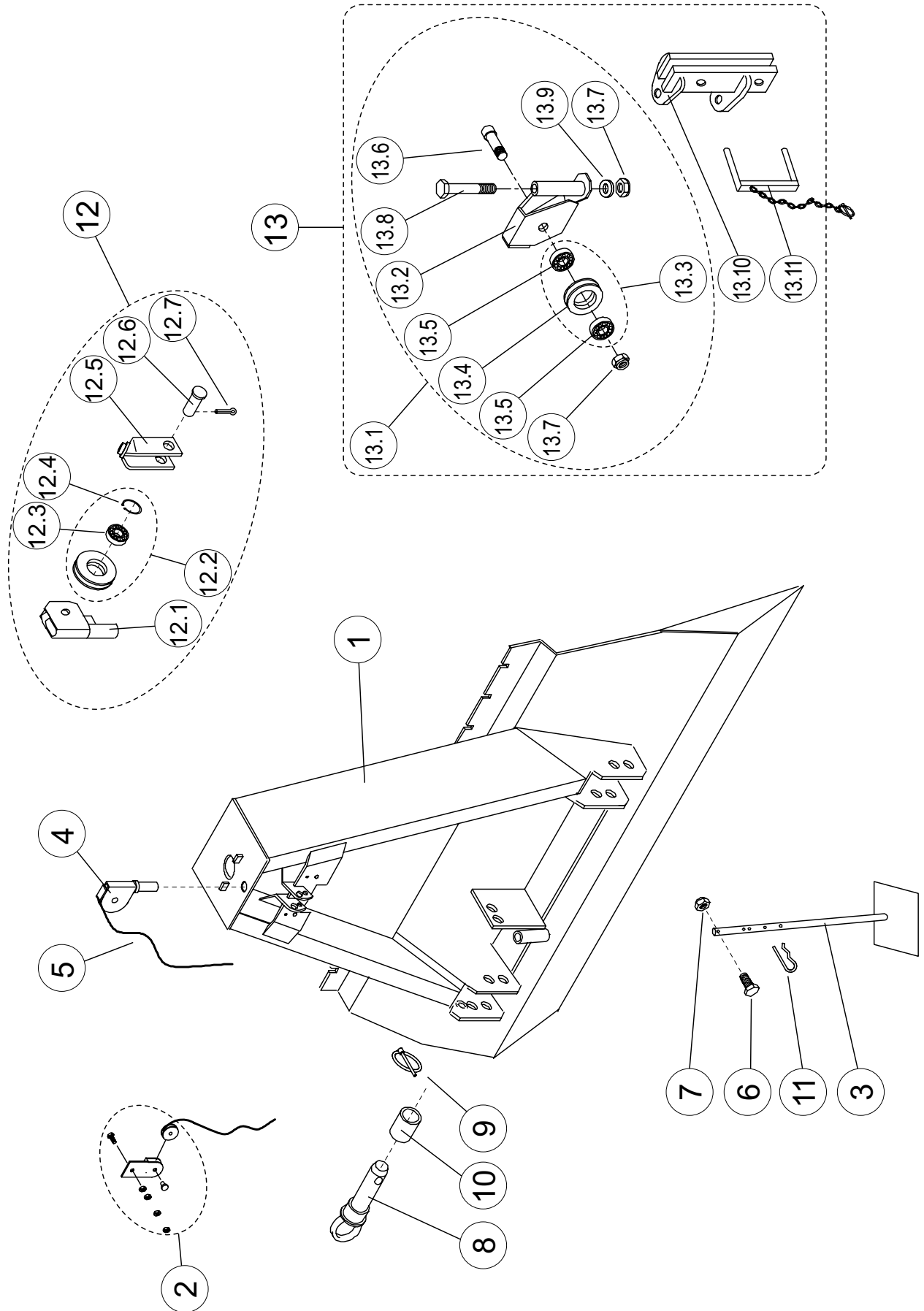

JL 351P

FRAME

Part	Order no	Description	Remarks	Qty
1	23181761	Frame		1
2	43020775	Snatch block	complete	1
3	43020700	Support leg		1
4	42721050	Snatch block		1
5	54824099	Clutch rope	5,00 m	1
6	52060050	Screw	M6X40 DIN933 88ZN	1
7	52117066	Lock nut	M6 DIN985 8ZN	1
8	92820182	Pin		2
9	52842150	Ring cotter	10X45	2
10	40293797	Bushing	45X76	2
11	52842143	Cotter	5X105	1
12	03181104	Diverting pulley	complete	1
12.1	33181116	Frame		1
12.2	40582165	Diverting pulley	complete	1
12.3	54511159	Slotted sealed ball bearing		1
12.4	52231123	Circlip	62x2,0 DIN472	1
12.5	43180560	Finger guard		1
12.6	94620861	Pin		1
12.7	52813219	Split pin	6X40 DIN94 ZN	1
13	03032400	Lower diverting pulley	complete	1
13.1	33032012	Diverting pulley		1
13.2	23032022	Frame		1
13.3	03032480	Diverting pulley	complete	1
13.4	43032036	Diverting pulley		1
13.5	54511159	Slotted sealed ball bearing		2
13.6	43031434	Screw		1
13.7	52117249	Lock nut	M24 DIN985 8ZN	2
13.8	52062450	Hexagonal socket head screw	M24x240 DIN912 88ZN	1
13.9	52200102	Washer	M24 DIN126 58ZN	2
13.10	43401025	Adjusting bracket		1
13.11	03403110	Locking device		1

JL 351P

MACHINERY

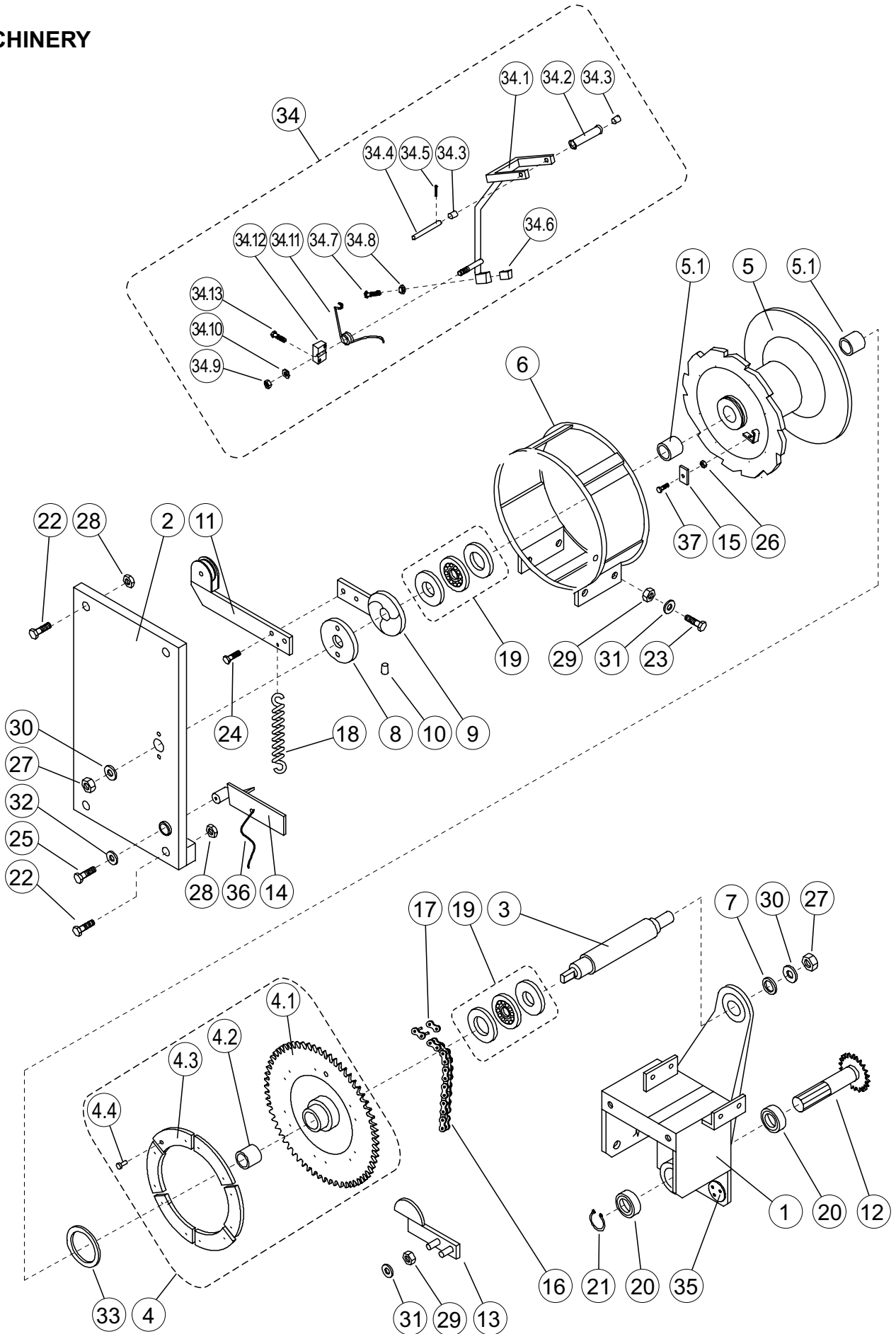

JL 351P

MACHINERY

Part	Order no	Description	Remarks	Qty
1	23010523	Frame		1
2	42722918	Front plate		1
3	32722753	Axle		1
4	43010446	Sprocket	complete	1
4.1	33010455	Sprocket		1
4.2	54562053	Slide bearing		1
4.3	42722744	Friction piece		6
4.4	52830015	Rivet	1/4X3/4 MS DIN 7338-B	12
5	33000084	Drum	complete	1
5.1	54562053	Slide bearing		2
6	33000621	Drum cover		1
7	43000678	Ring	D65	1
8	32722779	Clutch half		1
9	42723114	Clutch half		1
10	40660235	Roll		3
11	42722785	Clutch lever		1
12	43010479	Splined shaft		1
13	43000108	Chain tightener		1
14	43000645	Drum lock latch		1
15	42723163	Key		1
16	54820584	Roller chain	69 links	1
17	54820527	Chain link		1
18	94612082	Tension spring	DU26	1
19	54542063	Ball thrust bearing		2
20	54511274	Slotted sealed ball bearing		2
21	52230067	Circlip	35X2,5 DIN471	1
22	52062106	Screw	M16X30 DIN933 88ZN	4
23	52060225	Screw	M10X25 DIN933 88ZN	4
24	52060209	Screw	M10X16 DIN933 88ZN	2
25	52060118	Screw	M8x16 DIN933 88ZN	1
26	52117082	Lock nut	M8 DIN985 8ZN	1
27	52110103	Nut	M24 DIN934 8ZN	2
28	52110079	Nut	M16 DIN934 8ZN	4

JL 351P

MACHINERY

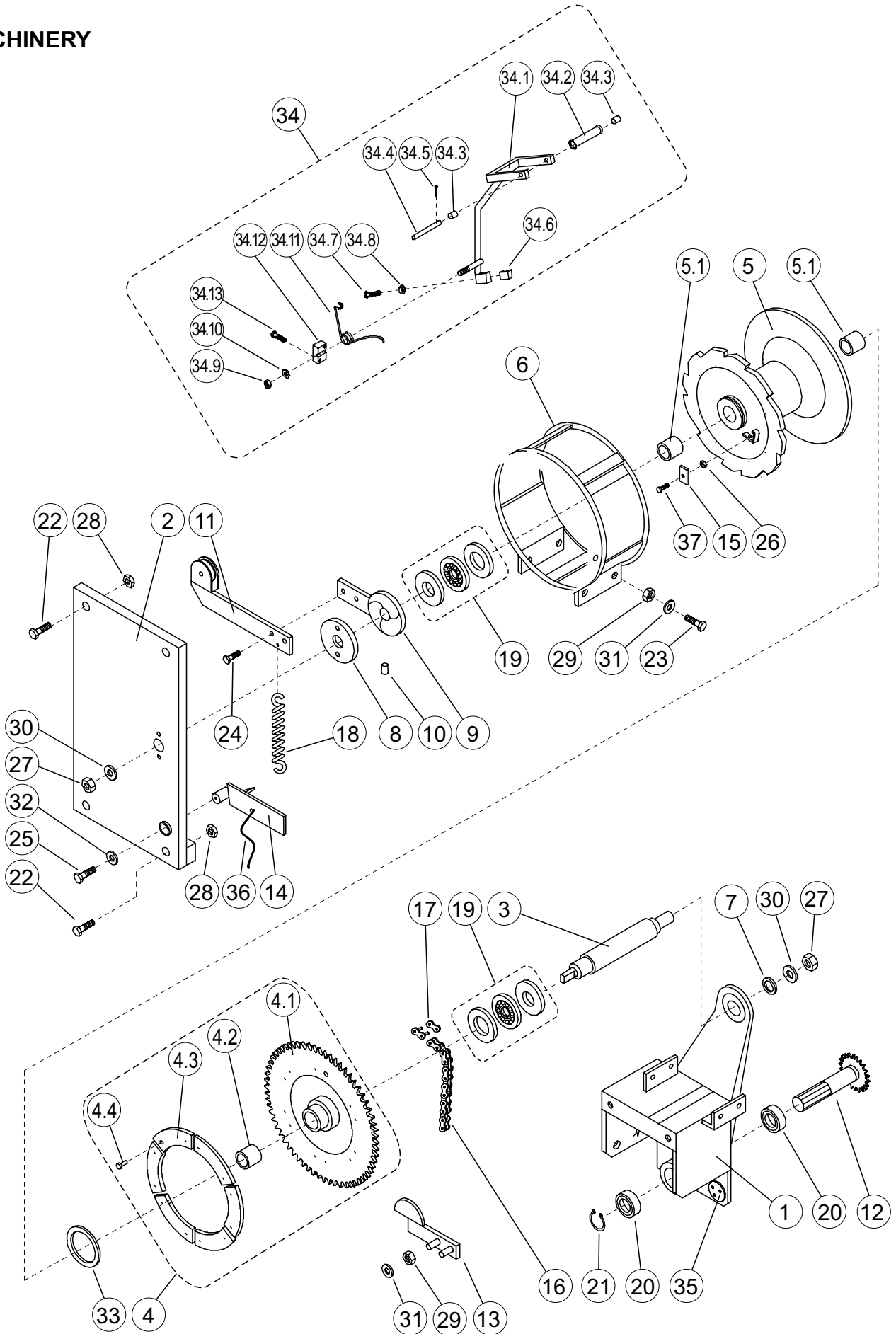

JL 351P

MACHINERY

Part	Order no	Description	Remarks	Qty
29	52110046	Nut	M10 DIN934 8ZN	6
30	52200102	Washer	M24 DIN126 58ZN	2
31	52200045	Washer	M10 DIN126 58ZN	6
32	52200235	Washer	M8 DIN9021 58ZN	1
33	52390861	Felt seal	D50	1
34	43190420	Drum brake	complete	1
34.1	43190438	Frame		1
34.2	43001221	Roll		1
34.3	43183780	Bushing		2
34.4	43001239	Axle		1
34.5	52813094	Split pin	4X25 DIN94 ZN	1
34.6	42723197	Friction piece		1
34.7	52060258	Screw	M10X40 DIN933 88ZN	1
34.8	52110046	Nut	M10 DIN934 8ZN	1
34.9	52117108	Lock nut	M10 DIN985 8ZN	1
34.10	52200045	Washer	M10 DIN126 58ZN	1
34.11	94624046	Torsion spring	DU32,5	1
34.12	43010412	Fastening		1
34.13	52060514	Screw	M10X20 DIN933 88ZN	2
35	43100610	Eccentric piece		1
36	54824115	Latch rope	3,5 m	1
37	52060134	Screw	M8X40 DIN933 88ZN	1

JL 351P

43181577 PROTECTIVE SCREEN

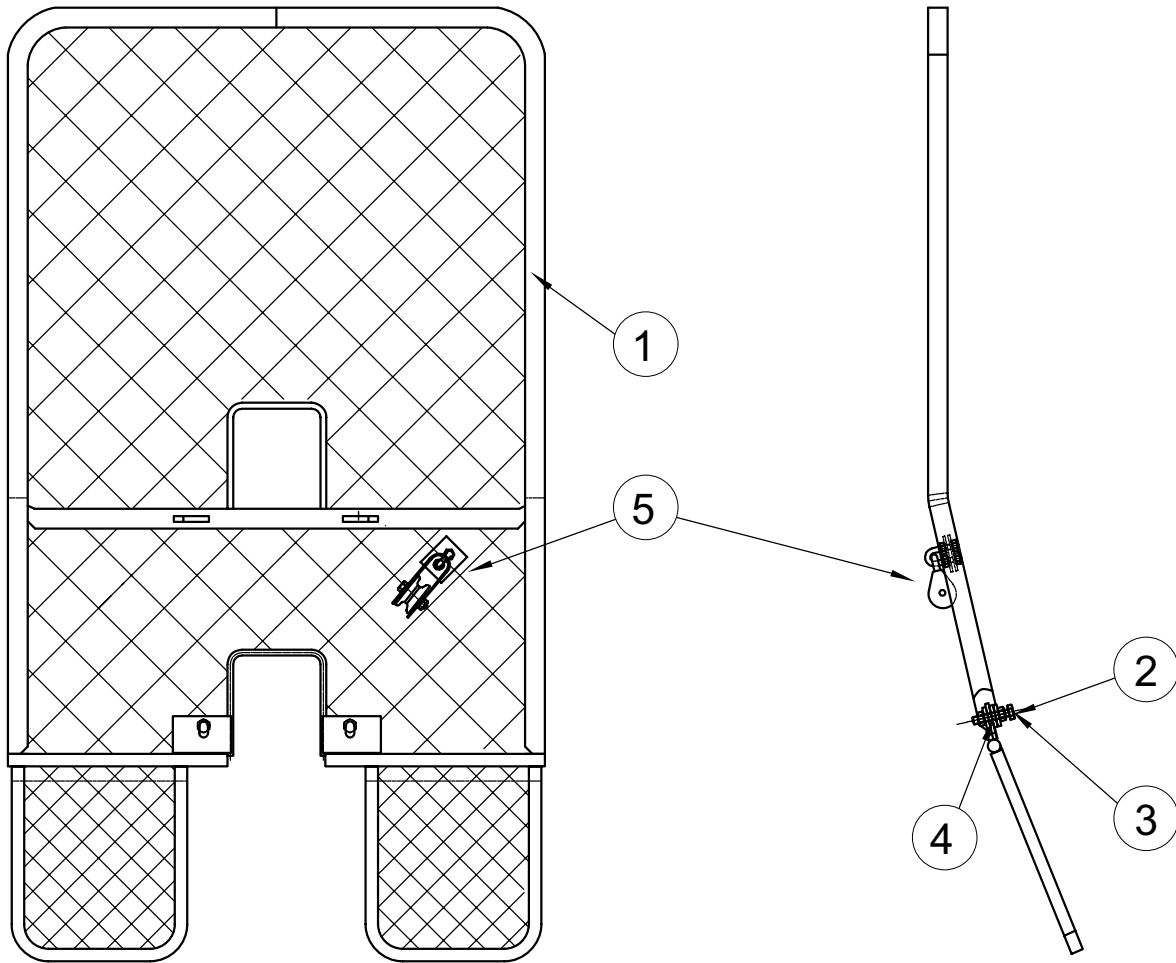

Part	Order no	Description	Remarks	Qty
1		Protective screen		1
2	52110046	Nut	M10 DIN934 8ZN	4
3	52060340	Screw	M10X50 DIN933 88ZN	2
4	52200490	Washer	M12 DIN 7349 ZN	4
5	43130137	Snatch block		1

JL 351P

LOWER PROTECTIVE SCREEN

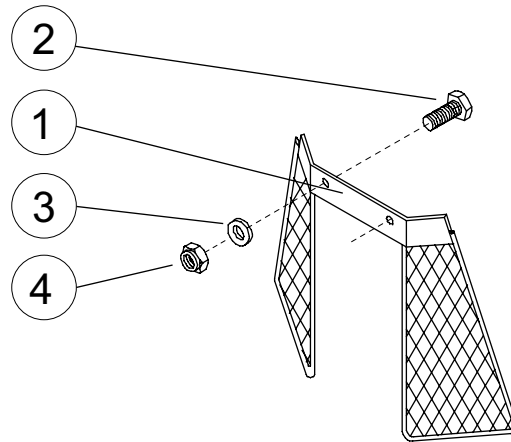

Part	Order no	Description	Remarks	Qty
1	43020502	Lower protective screen		1
2	52060225	Screw	M10X25 DIN933 88ZN	2
3	52200045	Washer	M10 DIN126 58ZN	2
4	52110046	Nut	M10 DIN934 8ZN	2

COVER OF THE UNIVERSAL SHAFT

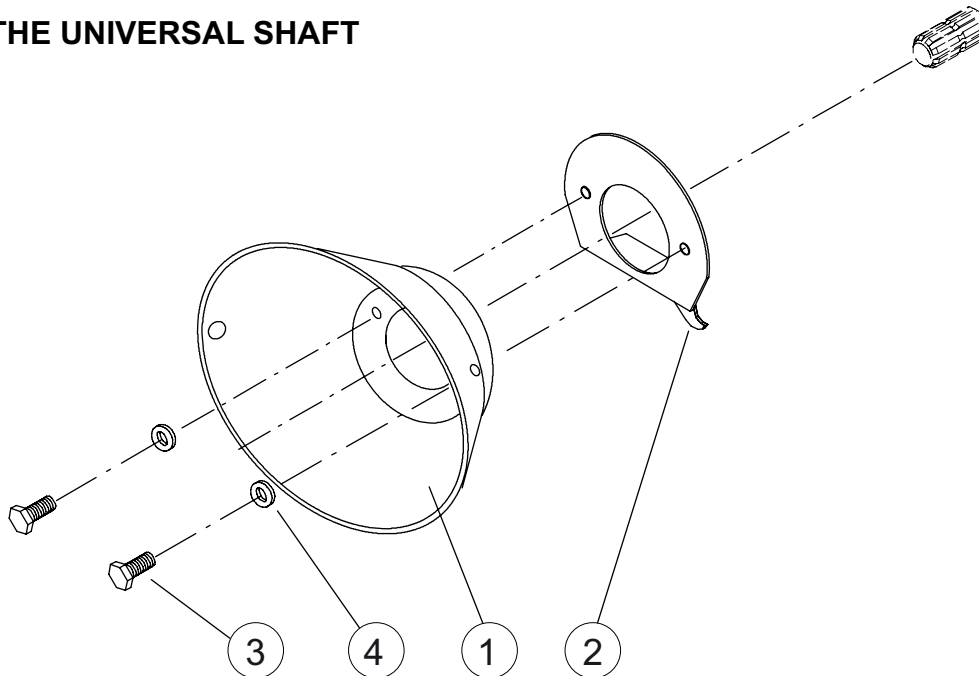

Part	Order no	Description	Remarks	Qty
1	43511780	Cover of the universal shaft		1
2	43402180	Fastener		1
3	52060100	Screw	M8X12 DIN933 88ZN	2
4	52200235	Washer	M8 DIN9021 58ZN	2

JL 351P

ACCESSORIES



LL

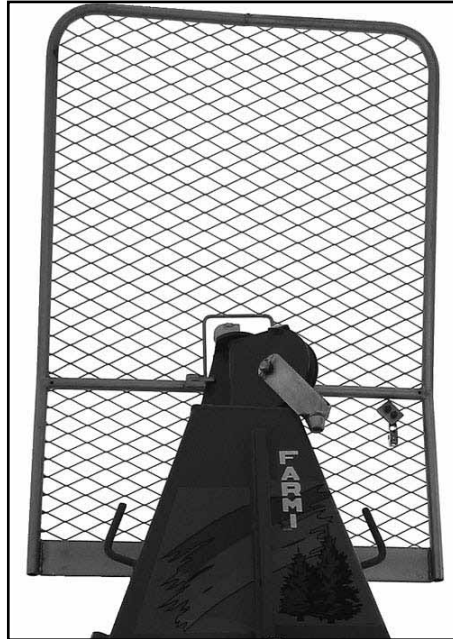

SV



HOF-4



ASV



ATP



TP14IH

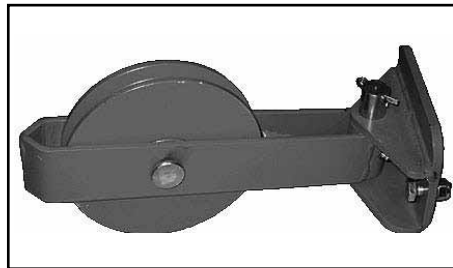

PLL

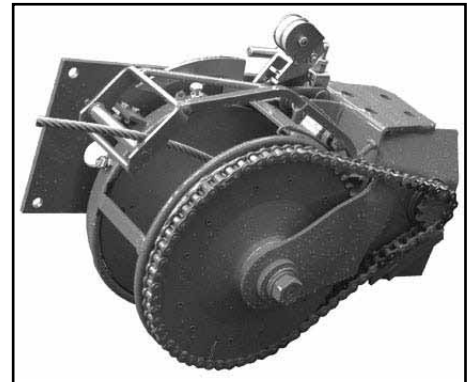

JK

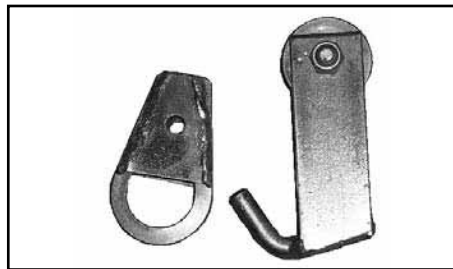

NK1

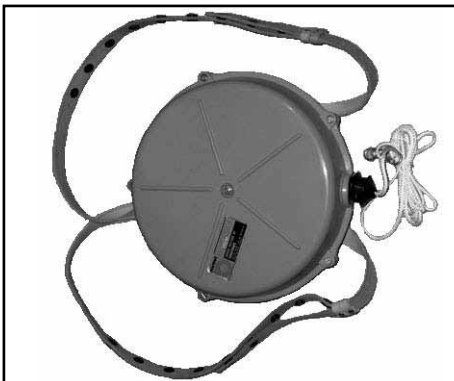

NK45

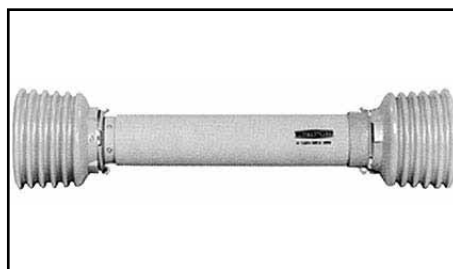

W2200



LK

JL 351P

ACCESSORIES

Part	Order no	Description
JK 351	03190469	Machinery 3,5 t
JK 501	03010501	Machinery 5 t
JK 501T	03010519	Machinery 5 t, with brake
JK 601	03100006	Machinery 6 t
JK601T	03110005	Machinery 6 t, with brake
ATP 500	33032012	Lower pulley D = 105 mm
ATP 500T	33031378	Lower pulley D = 153 mm
ATP 501	03032400	Lower pulley with frame, D = 105 mm
ATP 501T	03032410	Lower pulley with frame, D = 153 mm
ATP 601T	03035200	Lower pulley with frame, D = 180 mm
ATP650T	03402000	Lower pulley with frame, D = 180 mm
W 2100	54807706	PTO-shaft, 14 kW
W 2200	54807714	PTO-shaft, 24 kW
W 2300	54821012	PTO-shaft, 34 kW
W 2400	54823060	PTO-shaft, 47 kW
Belt TP14	54713037	Belt for TP14
TP14 IH	30118120	Self releasing pulley, max. 3,5 t, without belt
LK2-TK10	54817077	Notched hook
NK 1	42381558	Hook
NK 45	54824370	Rope drum
JK 208	54827019	Skidding chain L = 2,0 m
JK 248	54827043	Skidding chain L = 2,4 m
LL 2	54813159	Choker (cable 8-12 mm)
LL 4	54813167	Choker (cable 14 mm)
VAIJ D8	54824677	Cable, D = 8 mm, F = 44 kNm
VAIJ D10	54824032	Cable, D = 10 mm, F = 63 kNm
VAIJ D12	54824040	Cable, D = 12 mm, F = 90,7 kNm
VAIJ D14	54824057	Cable, D = 14 mm, F = 123,5 kNm
SV 300T	43181577	Protective screen
SV 600T	33130303	Protective screen
PLL 500	33031196	Cable winder (JL 501) D = 90 mm
PLL 600	43120542	Cable winder (JL 601/650) D = 90 mm
ASV 400	43020502	Lower protective screen
HOF-4	03151930	Hydraulic control, 2 cylinders
HOF-4G	03151940	Hydraulic control, 2 cylinders
HOF 501	03151280	Mounting kit
HOF 601T/650T	03151290	Mounting kit
HOF ALP 55-85	03151920	Mounting kit

WARRANTY

Farmi Forest Oy grants a 12-month warranty on all of its products, covering material and manufacturing faults. The warranty comes into effect on the product's delivery date.

The manufacturer is not liable for damages caused by:

- misuse of the product
- alterations or repairs made without the manufacturer's permission
- insufficient maintenance
- non-original parts

The warranty does not cover wearing parts.

Send faulty parts, carriage paid, to the manufacturer for inspection. Repairs will be conducted by Farmi Forest Oy or an authorized expert. The warranty is valid only if the bottom part of this page is filled in and returned to the manufacturer within 14 days of receipt of the product.

By returning the warranty certificate, you confirm that you have read and understood the instruction manual that came with the product.

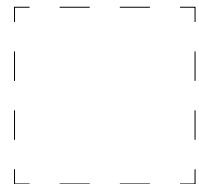

Farmi Forest Corporation
Ahmolantie 6
FIN-74510 IISALMI
FINLAND

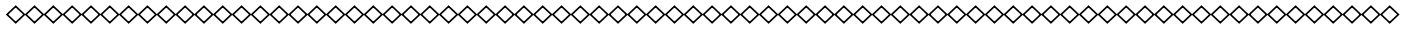

Date of delivery: _____ / _____ 20_____

Dealer: _____

Dealer's address: _____

Dealer's tel: _____

Product and type: _____

Serial number: _____

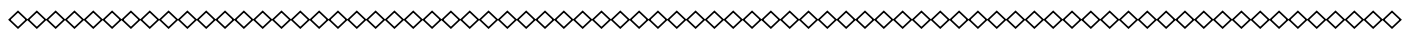

Return to the manufacturer

Date of delivery: _____ / _____ 20_____

Dealer: _____

Dealer's address: _____

Dealer's tel: _____

Customer: _____

Customer's address: _____

Customer's tel: _____

Product and type: _____

Serial number: _____

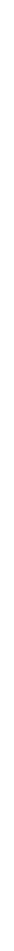



FARMI[®]
Forest

Farmi Forest Corporation
Ahmolantie 6
FIN-74510 Iisalmi, Finland
Puh. +358 (0)17 83 241
Fax. +358 (0)17 8324 372
www.farmiforest.fi